

This drawing is the property of Stansefabrikken Fredrikstad AS. Fredrikstad Norway and must not be transferred, lent or reproduced without an explicit written permission from the company

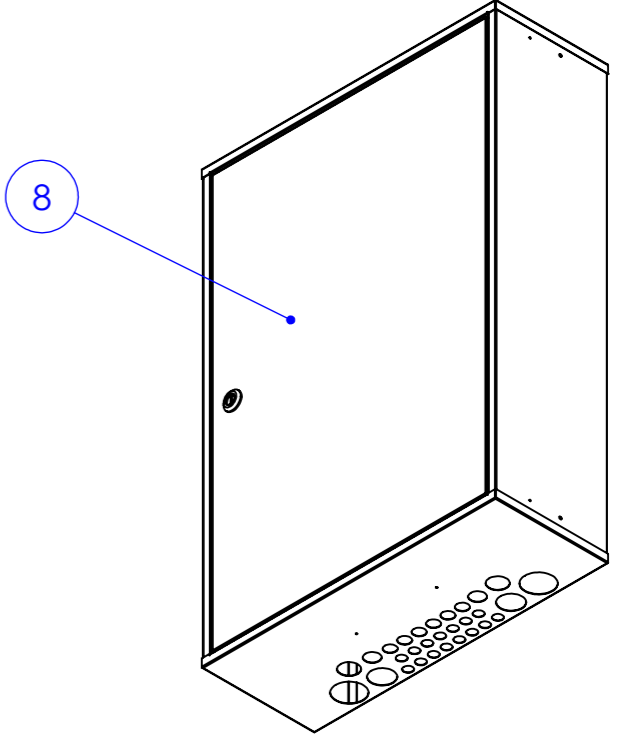

SECTION A-A

ITEM NO.	PART NUMBER	DESCRIPTION	QTY.
1	sff00540	Welded 2 row cabinet	1
2	sff00542	Fuse modul 2 row	1
3	sff00501	Meater mounting plate	1
4	sff00502	Fuse cover for 2 row	1
5	sff00579	Over curent circuit breaker	1
6	sff00503	Cover plate for over curenry circuit breaker	1
7	sff00504	Cabel cover plate	1
8	sff00509	Assembled 2 roew door	1
9	SFF1725549	KLB 24 GROUNDING RAIL	1
10	M3x16 DIN7985 torx	Machine screw Stainless steel, A4-80, ISO 14583	2
11	-	WASHER M3 DIN7980 ZN	2

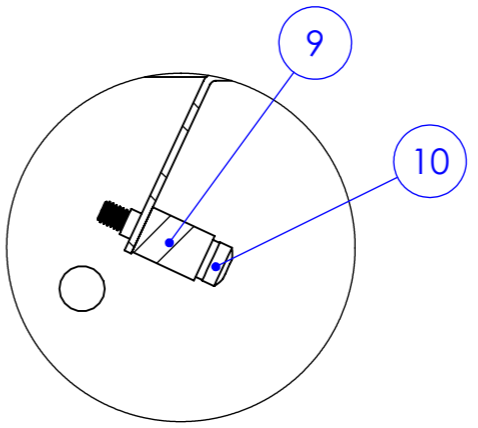
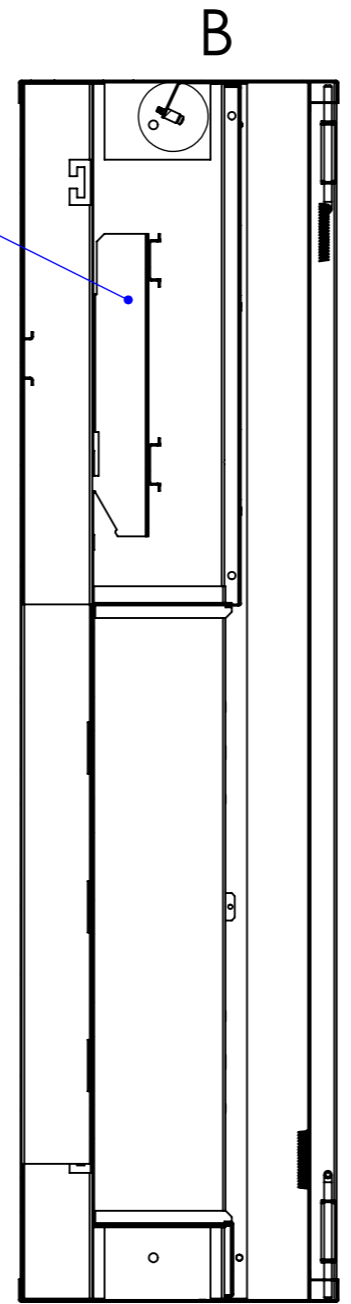
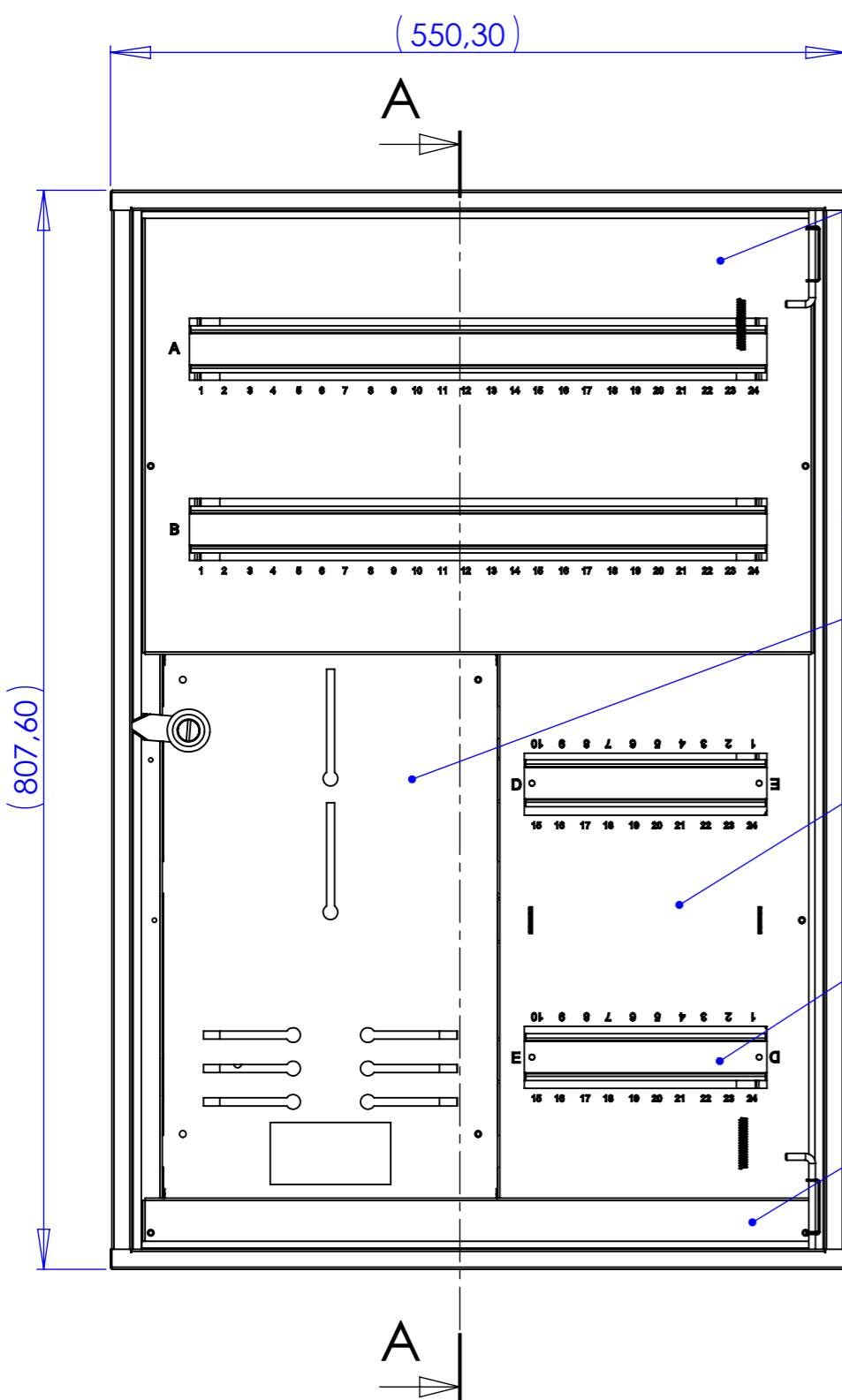
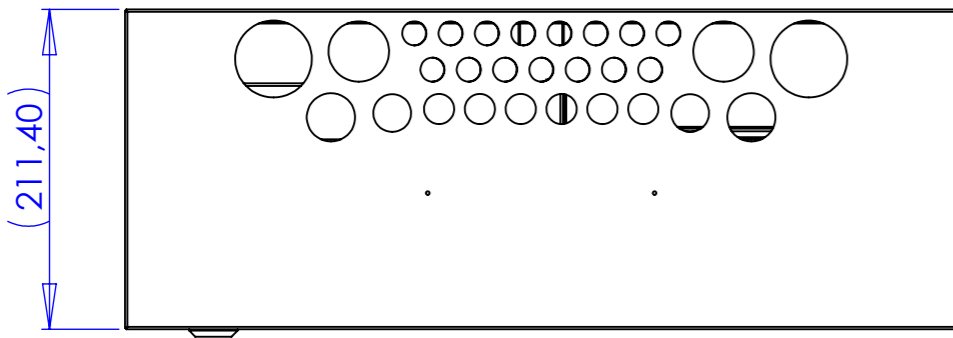

Surface	Material	Sheet thickness	Weigth
-	-	-	18281.81
Project	Tolerance	Units	Scale
FLEXI	NS-ISO 2768-1,M	mm, g	1:5
Department	Designer	2. Designer	Format
Stansefabrikken Products AS	SFP	GRA	A3
Logo	Description	Document status	
	FLEXI 2RS	RELEASED	
		Drawing no	
		sff00572	
		Rev.no	Sheet/Sheets
		--	1/2
		Date	
		2023-03-07	